

Liquid-Liquid Extraction Equipment

Jack D. Law and Terry A. Todd
Idaho National Laboratory

Liquid-liquid extraction (also called solvent extraction) was initially utilized in the petroleum industry beginning in the 1930's. It has since been utilized in numerous applications including petroleum, hydrometallurgical, pharmaceutical, and nuclear industries. Liquid-liquid extraction describes a method for separating components of a solution by utilizing an unequal distribution of the components between two immiscible liquid phases. In most cases, this process is carried out by intimately mixing the two immiscible phases, allowing for the selective transfer of solute(s) from one phase to the other, then allowing the two phases to separate. Typically, one phase will be an aqueous solution, usually containing the components to be separated, and the other phase will be an organic solvent, which has a high affinity for some specific components of the solution. The process is reversible by contacting the solvent loaded with solute(s) with another immiscible phase that has a higher affinity for the solute than the organic phase. The transfer of solute from one phase into the solvent phase is referred to as extraction and the transfer of the solute from the solvent back to the second (aqueous) phase is referred to as back-extraction or stripping. The two immiscible fluids must be capable of rapidly separating after being mixed together, and this is primarily a function of the difference in densities between the two phases.

While limited mass transfer can be completed in a single, batch equilibrium contact of the two phases, one of the primary advantages of liquid-liquid extraction processes is the ability to operate in a continuous, multistage countercurrent mode. This allows for very high separation factors while operating at high processing rates. Countercurrent operation is achieved by repeating single-stage contacts, with the aqueous and organic streams moving in opposite directions as shown in Figure 1.

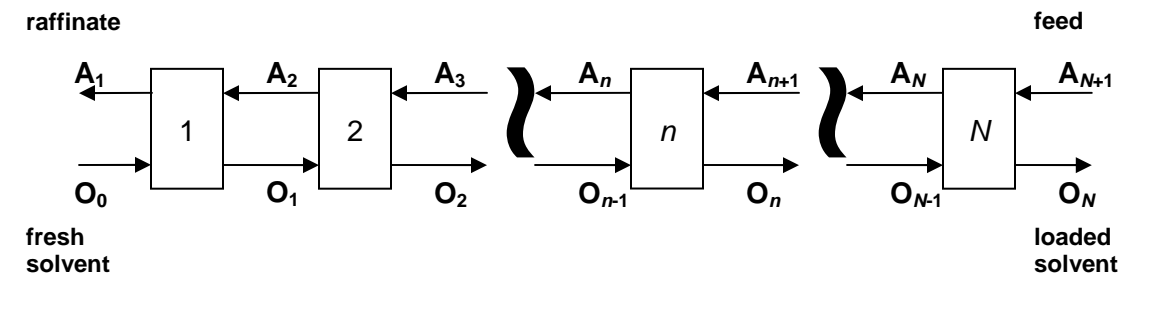

Figure 1. Countercurrent – multistage extraction process flow diagram

In this flow diagram, the aqueous feed stream containing the solute(s) to be extracted enters at one end of the process (A_{N+1}), and the fresh solvent (organic) stream enters at the other end (O_0). The aqueous and organic streams flow countercurrently from stage to stage, and the final products are the solvent loaded with the solute(s), O_N , leaving stage N and the aqueous raffinate, depleted in solute(s), leaving stage 1. In this manner, the concentration gradient in the process remains relatively constant. The organic at stage O_0 contains no solute(s), while the raffinate stream is depleted of solute(s). Streams A_n and O_{n-1} contain intermediate concentrations of the solute(s) and finally, streams A_{N+1} and O_N contain the highest concentration of the solute(s). The concentration of the solutes in a countercurrent process is shown graphically in Figure 2, where the orange color shows the relative concentration of the solute(s) in the process.

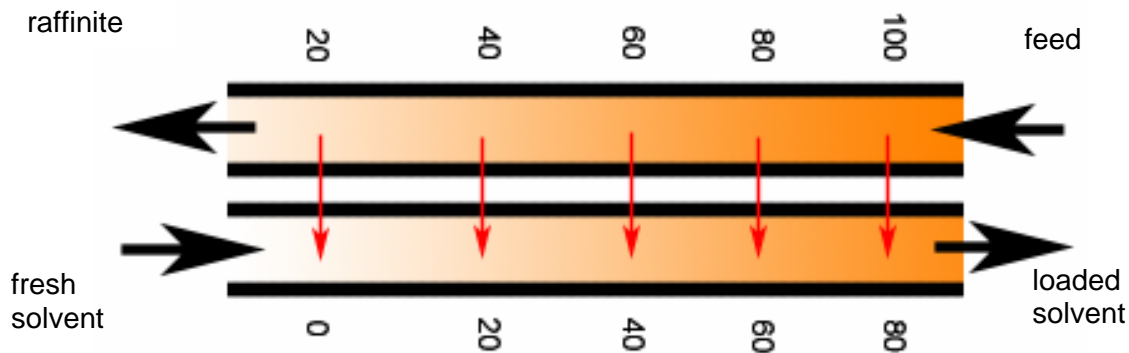

Figure 2. Countercurrent process concentration profiles

For the process to be economical, the solvent must be recycled. In order to recycle the solvent, the solute is subsequently stripped from the solvent, and the solvent is then recycled back to the countercurrent extraction process. This allows the solvent to be recycled indefinitely, until it has degraded (due to acid hydrolysis or radiolytic degradation) or the solvent composition has changed due to solubility in the aqueous phase.

While countercurrent processes could be performed in laboratory glassware, their primary advantage is to enable continuous processing at high throughputs. In order to achieve continuous processing, specific equipment is needed that can efficiently mix and separate the two phases continuously. In the nuclear industry, specific constraints, such as remote operation and maintenance must be considered, since the solutions processed are highly radioactive. There are three basic types of equipment used in industrial-scale nuclear solvent extraction processes: mixer-settlers, columns and centrifugal contactors. In selecting the type of equipment, a number of process parameters must be considered. These include:

- Process foot print and building size/height
- Operational flexibility (continuous long-term operation or frequent start-stop operation)
- Solvent inventory and in-process volume holdup
- Degradation of solvents due to radiolysis/hydrolysis
- Time required to reach steady-state operation
- Potential to operate complex multi-cycle processes linked together
- Tolerance to cross-phase entrainment
- Tolerance to solids in process solutions
- Tolerance to process upsets
- Process chemistry (e.g. kinetics of valance adjustment)
- Mass transfer kinetics
- Remote maintenance capabilities
- Criticality constraints

A detailed description and comparison of the three types of equipment is provided to further elucidate applicability of each of these equipment types.

Mixer-Settlers

This device consists of a small mixing chamber followed by a larger gravity settling chamber as shown in Figure 3.

Each mixer-settler unit provides a single stage of extraction. The two phases enter the mixing section where they are mixed using an impeller. The two-phase solution flows into the settling section where they are allowed to separate by gravity due to their density differences. Typical mixer settlers have mixing times on the order of a few minutes and settling times of several minutes. The separate phases exit the settling section by flowing over a weir (organic solution) or through an underflow then over a weir (aqueous phase). The separation interface is controlled by the height of the weirs on the outlets of the settler section. Only minimal instrumentation is required and mechanical maintenance is limited to occasional mixing motor replacement. In a countercurrent process, multiple mixer settlers are installed with mixing and settling chambers located at alternating ends for each stage (since the outlet of the settling sections feed the inlets of the adjacent stage's mixing sections). Mixer-settlers are used when a process requires longer residence times and when the solutions are easily separated by gravity. They require a large facility footprint, but do not require much headspace, and need limited remote maintenance capability for occasional replacement of mixing motors. (Colven, 1956; Davidson, 1957)

Figure 3. Diagram of a mixer-settler

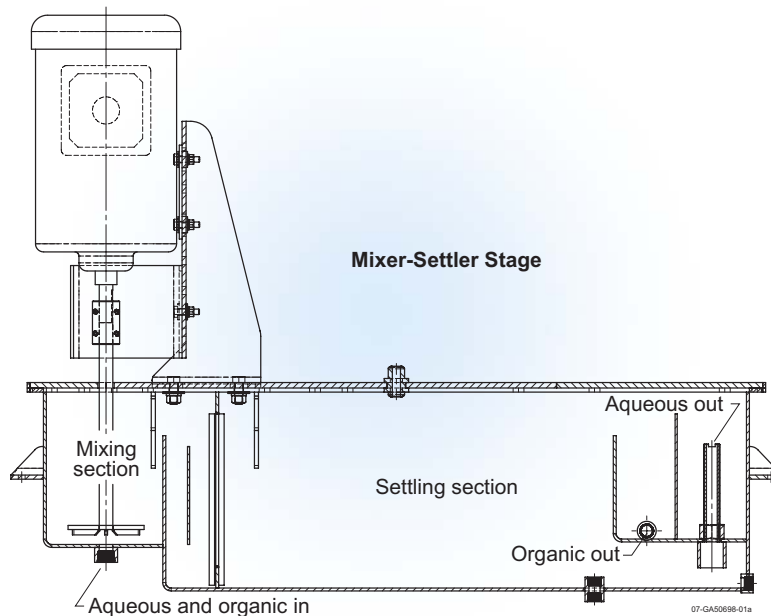

Columns

There are two basic types of columns employed industrially, packed columns and pulse columns with plates or trays.

Packed columns are filled with some type of packing material, such as Raschig Rings, to create a tortuous path for the two solutions as they flow through the column (typically aqueous feed downward and solvent upward), ensuring that the two phases are in constant contact. Packed columns have no moving parts and are relatively simple to operate, but they are not very efficient. Since columns do not have discrete stages, such as mixer-settlers or centrifugal

contactors, the number of stages is determined by the height of a theoretical stage. For most packed columns, this height to achieve one theoretical stage of extraction is usually several feet, meaning that a countercurrent process utilizing several stages to effect a given separation factor, would require very tall columns.

To reduce the height of a theoretical stage in the column, other packing (trays or perforated plates) are used and mechanical energy is applied to force the dispersed phase into smaller droplets, improving mass transfer. The most common type of column used, particularly in the nuclear industry, is the pulse column.

In a pulse column, liquids are continuously fed to the column and flow counter-currently, as is done with a packed column, but mechanical energy is applied to pulse the liquids in the column up and down. This is normally done by injecting pressurized air into a pulse leg that pushes liquid into the column, then venting the pulse leg to fill the pulse leg with solution from the column. The pulse action lifts and lowers the solution in the column, usually only a few inches. The column is filled with perforated plates or other plates to promote droplet formation as the dispersed phase is pushed through the plates. This pulsing action reduces droplet size of the dispersed phase and improves mass transfer. A perforated plate pulse column is shown in Figure 4. There are a number of plate designs used. Early pulse columns used sieve plates, which are flat plates with holes drilled into them. A more effective plate is the nozzle plate, which has different contours on the top and bottom of the plate (making it directional, in that it must be configured according to the continuous phase in the column). The French and Japanese pulse columns employ a “disk and donut” configuration, where the plates are solid (no openings) but the alternating plates enable effective contacting of the phases.

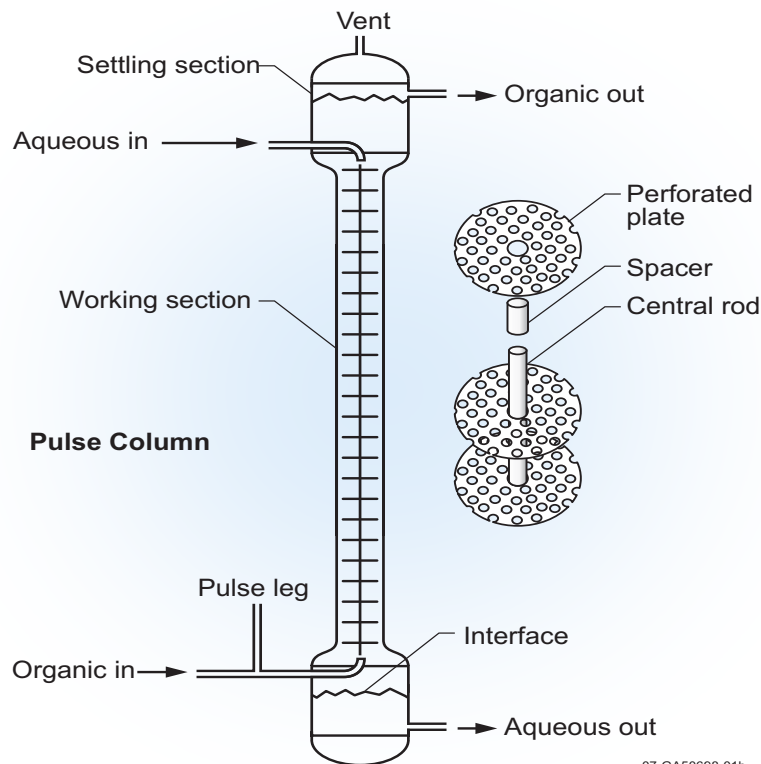

07-GA50698-01b

Figure 4. Pulse Column with perforated plates

The separation interface is controlled during column operation using bubble probes in the disengaging section. The probes are interfaced to a controller that drains heavy phase from the bottom of the column. The bubble probes allow operators to monitor the “weight” of the column, which gives them a good indication of column performance, by determining the ratio of heavy and light phases in the column. In addition, pulsing devices and pulse speed controllers are required as pulse frequency and amplitude must be controlled during operation. Periodic maintenance is required only for the pulsing equipment, which is located out of cell, above the columns. Pulse columns are used when a process requires intermediate residence times, as residence time is easily varied by adjusting flowrate. They require a small facility footprint, but do require much headspace (typically 40-50 feet). Pulse columns do not need remote maintenance capability, as all moving parts (pulser equipment) are located outside the shielded cell. Extensive literature has been published on pulse columns (Sege, 1954; Geier, 1954; Richardson, 1961)

Centrifugal Contactors

Centrifugal contactors, like mixer-settlers, are discrete-stage units, providing one stage of extraction per unit and are readily linked together as each rotor pumps separated fluids to the next stage inlet in each direction. The primary difference between a centrifugal contactor and a mixer-settler is the separation of the two-phase mixture. Centrifugal contactors employ a spinning rotor that 1) intensely mixes the two phases and 2) separates the two phases inside the rotor where the centrifugal forces can be as high as 300 g, resulting in efficient and fast phase separation. The separated phases exit the contactor by overflow and underflow weirs, similar to a mixer-settler. A cutaway view of an operating centrifugal contactor is shown in Figure 5.

Centrifugal contactors have high single stage efficiency (routinely greater than 95% of theoretical for chemical processes with rapid kinetics). Process flow interruptions cause no loss of process concentration profiles if centrifugal contactor rotors are kept spinning. Thus centrifugal contactor based processes can be “paused” for a period of time sufficient to re-establish flow or even replace a motor without significant loss of product or rework. Centrifugal contactors require a minimum of instrumentation for process operation. Computer control via commercial software allows monitoring of motor amperage, rotor rpm, inlet flow rates, temperatures and many other process parameters. Centrifugal contactors are used when a process requires short residence times, on the order of several seconds. They require a small facility footprint, and minimal headspace, but do require remote maintenance capability, for periodic removal of the motor and/or rotor.

Centrifugal contactors have been the subject of much recent development work, over the past 40 years, while the designs of pulse column and mixer-settlers has changed little over the same time period (Leonard, 1988; Jubin 1988; Meikrantz, 2001). Early designs included a paddle-wheel to mix the phases below the spinning rotor (Watts, 1977). This precluded removal of the rotor assembly, and so the annular centrifugal contactor was developed, which allowed the motor and rotor assembly to be easily removed (Bernstein, 1973). Other designs included multistage units, units for low-mix applications (higher phase separation), and clean-in-place units that have an array of internal spray nozzles to facilitate solids removal, if necessary. (Drain, 2003; Meikrantz, 1996; Macaluso, 1999)

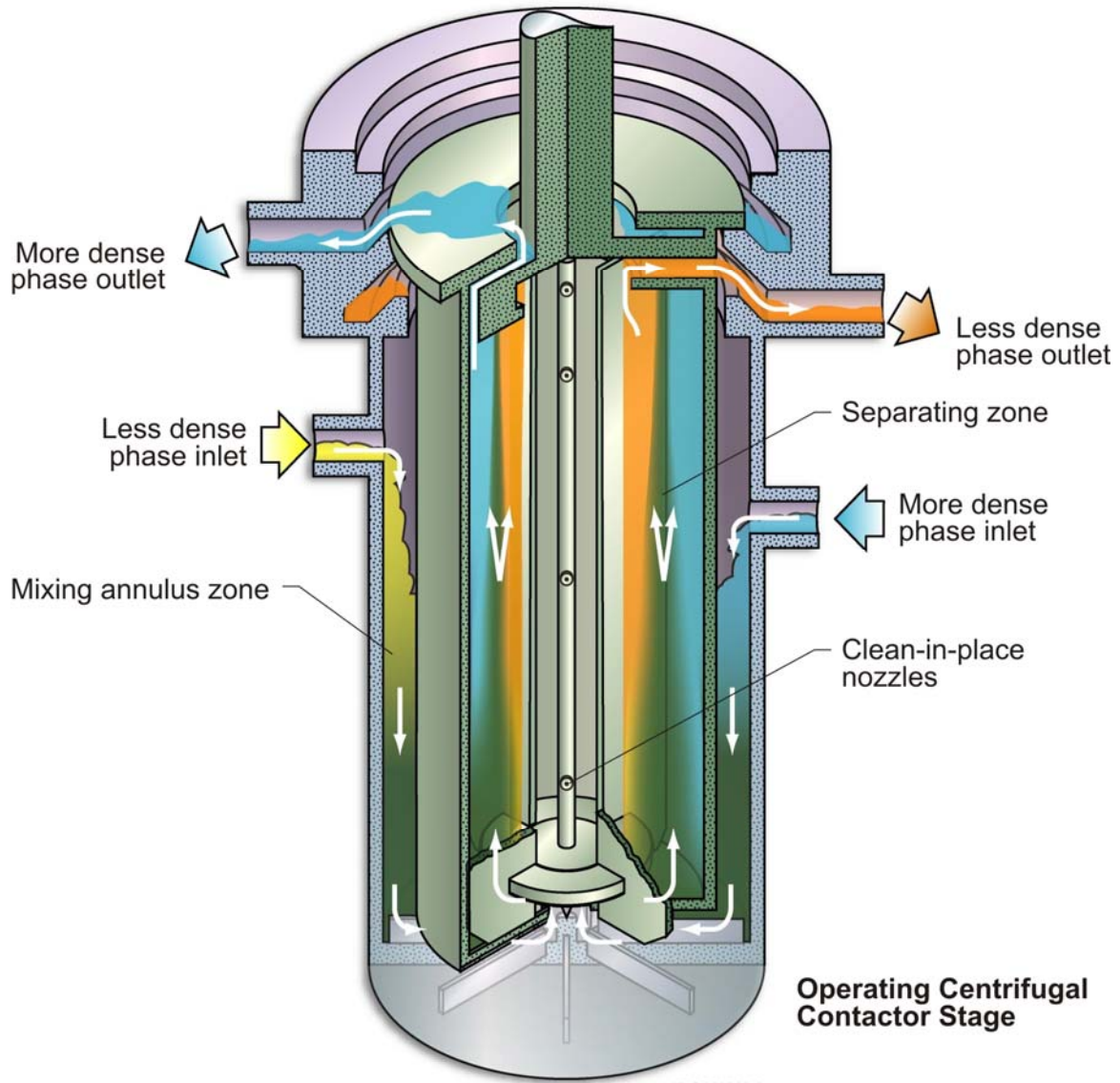

Figure 5. Cutaway view of an operating centrifugal contactor

Comparison of Contactors

Solvent extraction contacting equipment has been extensively studied and employed for the past 50 years. Each type of equipment has been proven over many years of operation and has inherent advantages and disadvantages (Cooley, 1962). The type chosen for a particular process application should be based on several factors *vide supra*. These include: criticality constraints, process (holdup) volume, process complexity (operability), reliability, maintenance philosophy, throughput, costs and performance issues such as solvent exposure (contact time), solids tolerance, flow rate turndown, equilibrium upset resistance, and process kinetics. An in-depth review and comparison of packed columns, pulse columns, mixer-settlers and centrifugal contactors for the Hanford PUREX plant was performed (Jealous, 1951). Later another comprehensive review was performed at Pacific Northwest Laboratories (Geier, 1977) and another review performed as part of the DOE Plutonium Technical Exchange Committee (Todd, 1998). A summary of the comparisons from this committee is shown in Table 1.

Table 1. Comparison of Mixer-Settler, Pulse Column and Centrifugal Contactors

Criteria	Ratings ^a			Comments
	Mixer-settler	Pulse Column	Centrifugal Contactor	
Long residence time ^b	5	4	1	
Short residence time ^c	1	2	5	
Building headroom	5	1	5	
Floor space required	1	5	3	May be small percentage of total floor area.
Instrumentation/control	5	4	5	
Ease of scale-up	3	3	5	
Low hold-up volume	2	3	5	
Equipment reliability	4	5	3	
Equipment capital cost	4	5	4	May be insignificant in relation to building cost.
Process flexibility ^d	4	3	5	
High throughput	2	5	5	Based on criticality safe by geometry equipment.
Ability to tolerate solids	2	5	2	
Reach steady state quickly	2	3	5	
Rapid restart	5	2	5	After temporary shutdown.

a. 5 = superior, 4 = good, 3 = average, 2 = below average, 1 = poor.

b. Considered an advantage when process chemistry requires long residence time.

c. Considered an advantage when solvent degradation is a concern.

d. Process flexibility includes such factors as the range of O/A flow ratio, the turndown in flowrate, and the ease with which the location of feed and product streams can be changed.

Industrial Reprocessing Experience

United States

Four industrial-scale nuclear reprocessing facilities were built in the United States, for defense purposes, that employed the PUREX process to separate and recover uranium and/or plutonium. These facilities were the H-canyon and F-canyon at Savannah River Site, The PUREX plant at Hanford, and the Idaho Chemical Processing Plant in Idaho.

Savannah River H and F-Canyon facilities

The Savannah River H-Canyon began operations in 1953 and was used to recover high-enriched uranium and neptunium from spent aluminum-clad reactor fuel. It utilized large mixer-settler banks for the PUREX process. The H-canyon is the only industrial-scale reprocessing facility still operational in the United States, as of 2008.

The Savannah River F-Canyon was originally meant to be a redundant facility to H-canyon, but was used to recovery plutonium from reactor targets. It began operation in 1954 and like H-Canyon, used large mixer-settlers. In the mid 1960's a bank of 25-cm centrifugal contactors were installed in the first-cycle extraction process to minimize solvent damage from radiolysis. The F-Canyon extraction operations were terminated in 2002, after nearly 50 years of operation. (Watts, 1977; Fernandez, 2000; www.globalsecurity.org)

Hanford PUREX plant

The Hanford PUREX plant operated from 1956 to 1986 to separate uranium, plutonium and neptunium from Hanford reactors. It replaced the Hanford REDOX facility, which utilized packed columns and required a "penthouse" extension to the facility to accommodate the height of the columns. The use of pulse columns in the PUREX plant resulted in a 50% reduction in height to achieve the same level of separations efficiency as the REDOX facility. An extensive research and development program of over 50 man-years of effort was undertaken from 1950-1953 to develop pulse column technology for the PUREX plant. (Courtney, 1954; Gerber 1993)

Idaho Chemical Processing Plant

The Idaho Chemical Processing Plant began operation in 1953 and used packed columns with methyl isobutyl ketone (hexone) as the solvent. In 1957, a new first cycle was added which utilized pulse columns and tributylphosphate in dodecane as the solvent. The packed columns utilizing hexone became the second and third cycle extraction processes. The first cycle solvent wash operations were performed in a series of mixer-settlers. Extraction operations were performed on numerous fuel types including zirconium, aluminum, stainless steel and graphite. During ROVER graphite fuel processing, the graphite was burned, the ash dissolved in nitric and hydrofluoric acid and the solution processed contained significant solids loading. No operational problems with first cycle pulse column operation were observed. A new fuel reprocessing facility was under construction in 1991, when fuel reprocessing in Idaho was terminated by the DOE. This facility included three cycles of TBP extraction using pulse columns. (Wagner, 1999)

Three commercial nuclear reprocessing facilities were built in the U.S., however, only one ever operated with spent nuclear fuel. These facilities were the West Valley Nuclear Fuel Services plant, the GE- Midwest Fuel Recovery Plant (Morris, II), and the Allied General Nuclear Services Barnwell facility.

West Valley

The West Valley Nuclear Fuel Services plant utilized pulse columns for solvent extraction processing. The plant operated from 1966 until 1972 and was the only commercial reprocessing facility that operated in the U.S. (Sinclair)

Midwest Fuel Recovery Plant

The Midwest Fuel Recovery Plant built by General Electric in Morris, Illinois, utilized one cycle of solvent extraction in pulse columns, and then used a fluoride volatility process to convert UO_3 to UF_6 and further purify it from impurities. The plant was completed in 1968 and GE withdrew the license application to the NRC in 1972. The plant never operated due to close coupled unit operations and problems associated with handling solid uranium in the feed to the volatility process. (Zentner, 2005)

AGNS Barnwell Facility

The Barnwell facility was designed have a 1500 MTHM/yr throughput capacity, larger than any nuclear fuel reprocessing plant in the world. It utilized a multi-stage centrifugal contactor to make the initial separation of plutonium and uranium from fission products, and then used pulse columns to partition uranium from plutonium and for separate uranium and plutonium purification cycles. The Barnwell facility was shutdown in the late 1970's and permanently closed in the early 1980's without ever processing spent nuclear fuel. (Benedict, 1982)

International

France

The LaHague reprocessing facility in France has been reprocessing commercial fuel since 1976 in the UP-2 plant (originally 400 MT/yr, then throughput was increased to 800 MT/yr), and added another plant (UP-3) in 1990. Each plant has a throughput of 800 MTHM/yr and use combinations of pulse columns, mixer-settlers and/or centrifugal contactors. A summary of the equipment types used in both facilities is given in Table 2. (Drain, 2003)

Table 2. Liquid-liquid extraction equipment in the La Hague reprocessing plants

Plant	Process Section	Process Equipment
UP-3/ UP-2 800	1st extraction cycle: highly active section	Annular pulse columns
UP-3	1st extraction cycle –U/Pu separation	Mixer-settler bank
UP-2 800	1st extraction cycle – U/Pu separation	Annular pulse columns
UP-3/ UP-2 800	1st extraction cycle – U stripping	Mixer-settler bank
UP-3/ UP-2 800	Uranium purification	Mixer-settler bank
UP-3	Plutonium purification	Pulse columns
UP-2 800	Plutonium purification	Centrifugal contactors
UP-3/ UP-2 800	Solvent regeneration	Mixer-settler bank

Japan

The Tokai reprocessing plant has been in operation since 1975 and includes three cycles of solvent extraction using only mixer-settlers. The Rokkasho reprocessing plant is undergoing final checkout testing with spent fuel, expecting to start full commercial operations in 2009. This plant is designed by AREVA and is very similar to the UP-3 plant design at LaHague. The Rokkasho plant utilizes annular pulse columns for first cycle extraction and plutonium partitioning. Mixer-settlers are used for the uranium and plutonium purification cycles as well as solvent washing.

United Kingdom

The Thermal Oxide Reprocessing Plant (THORP) was commissioned in 1994 and was designed for a throughput of 7 MT/yr in the headend processing section and 5 MT/yr in the separations portion of the plant. The THORP plant utilizes pulse columns in the first cycle HA process and in the plutonium purification cycle. Mixer-settlers are used in the first-cycle solvent wash and the uranium purification cycle. (Phillips, 1999)

Summary

Solvent extraction processing has demonstrated the ability to achieve high decontamination factors for uranium and plutonium while operating at high throughputs. Historical application of solvent extraction contacting equipment implies that for the HA cycle (primary separation of uranium and plutonium from fission products) the equipment of choice is pulse columns. This is likely due to relatively short residence times (as compared to mixer-settlers) and the ability of the columns to tolerate solids in the feed. Savannah River successfully operated the F-Canyon with centrifugal contactors in the HA cycle (which have shorter residence times than columns).

All three contactors have been successfully deployed in uranium and plutonium purification cycles. Over the past 20 years, there has been significant development of centrifugal contactor designs and they have become very common for research and development applications. New reprocessing plants are being planned in Russia and China and the United States has done preliminary design studies on future reprocessing plants. The choice of contactors for all of these facilities is yet to be determined.

References

1. Benedict, M., Pigford, T. H., and Levi, W. H., Nuclear Chemical Engineering, 2nd Ed., McGraw-Hill, New York, 1982.
2. Bernstein, G. L., et al., "A High-Capacity Annular Centrifugal Contactor" *Nuclear Technology*, 20, 1973.
3. Colven, T. J. Jr., "Mixer-Settler Development-Operating Characteristics of a Large-Scale Mixer-Seller," Savannah River Laboratory, DP-140, 1956.
4. Cooley, C. R., "Liquid-Liquid Solvent Extraction Contactors- A Literature Survey," HW-74532, 1962.
5. Courtney, J. J., and Clark, B. E. Jr., "An Introduction to the PUREX Plant, Hanford Atomic Projects Operations, HW-32413, 1954.
6. Davidson, J. K., et al., "Application of Mixer-Settlers to the PUREX Process," TID-7534, Book 1, 1957.
7. Drain, F., et al., "Forty years of Experience with Liquid-Liquid Extraction Equipment in the Nuclear Industry," Waste Management Conference 2003, Tucson, AZ, 2003.
8. Fernandez, L. P., "Savannah River Site Canyons – Nimble Behemoths of the Atomic Age," Westinghouse Savannah River Company, WSRC-MS-2000-00061, 2000.
9. Geier, R. G., "Application of the Pulse Column to the PUREX Process, USACC, Report TID-7534, 1954.
10. Geier, R. G., "Solvent Extraction Equipment Evaluation Study – Part 1," Battelle Northwest Laboratory, BNWL-2186 Pt. 1, 1977.
11. Gerber, M. S., "A Brief History of the PUREX and UO₃ Facilities," Westinghouse Hanford Company, WHC-MR-0437, 1993.
12. http://www.globalsecurity.org/wmd/library/report/enviro/eis-0219/eis0219_a.html
13. Jealous, A. C. and Stewart, E. C., "A Review of the Relative Merits of Packed Columns, Pulse Columns, Mixer-Settler Mechanism, and Centrifugal Contactors," Oak Ridge National Laboratory, CF-51-1-10, 1951.
14. Jubin, R. T., et al., "Developments in Centrifugal Contactor Technology, Oak Ridge National Laboratory, ORNL/TM-10768, 1988.
15. Leonard, R. A., "Recent Advances in Centrifugal Contactor Design," *Separation Science and Technology*, 23(12&13), 1988.
16. Meikrantz, D. H., et al., "Annular Centrifugal Contactors for Multiple Stage Extraction Processes," *Chem. Eng. Comm.*, Vol 188, 2001.
17. Meikrantz, D. H., et al., "Rotor Sleeve for a Centrifugal Separator," U.S. Patent # 5,571,070, 1996.
18. Macaluso, L. L., and Meikrantz, D. H., "Self-cleaning Rotor for a Centrifugal Separator," U.S. Patent # 5,908,376, 1999.
19. Phillips, C., "The Thermal Oxide Reprocessing Plant at Sellafield: Four Years of Successful Treatment of Irradiated Nuclear Fuel," Waste Management Conference 1999, Tucson, AZ, 1999.
20. Richardson, G. L. and Platt, A. M., *Progress in Nuclear Energy, Series IV, Technology Engineering and Safety*, Vol. 4, Pergamon Press, New York, 1961.
21. Sege, G. and Woodfield, F. W., *Chemical Engineering Progress*, 50(8), 1954.
22. Sinclair, E. E., et al., "Existing and Projected Plants and Processes for Thermal Reactor Fuel Recovery: Experience and Plans," OSTI, Conf-710901-12, date unknown.
23. Todd, T. A., et al., "Waste, Nuclear, Reprocessing and Treatment Technologies," Encyclopedia of Chemical Processing and Design, John J. McKetta editor, Marcell Dekker Inc., NY, Vol. 65, 1998.
24. Wagner, E. P., "Process Description and Operating History for the CPP-601/-640/-627 Fuel Reprocessing Complex at the Idaho National Engineering and Environmental Laboratory,

INEEL/EXT-99-00400, 1999.

25. Watts, C., "Solvent Extraction Equipment Evaluation Study – Part 2," Battelle Northwest Laboratory, BNWL-2186 Pt. 2, 1977.

26. Zentner, M. D., et al., "Nuclear Proliferation Technology Trends Analysis," Pacific Northwest National Laboratory, PNNL-14480, 2005.