

Quantifying the Risk of Nuclear Fuel Recycling Facilities

Dr. B. John Garrick

Short Course

Introduction to Nuclear Chemistry and Fuel Cycle Separations

Vanderbilt University

Nashville, Tennessee

December 16-18, 2008

Statement of Purpose

To discuss the safety analysis of nuclear fuel recycling plants and in particular to consider how quantitative risk assessment (QRA) might be applied to assess the radiological risk of the operation of such plants

Why QRA?

- **Completeness**
- **Context**
- **Realism**

Fundamentals of QRA

- **Step 1. Define the system in terms of what constitutes normal operation**
- **Step 2. Identify and characterize the sources of danger, that is, the hazards**
- **Step 3. Develop “what can go wrong” scenarios and “damage states”**

Fundamentals of QRA (cont'd)

- **Step 4. Quantify the likelihoods of the different scenarios and damage states**
- **Step 5. Assemble the scenarios into appropriate measures of risk**
- **Step 6. Interpret the results to guide the risk management process**

Basic Principles

- **Triplet definition of risk**
- **Scenarios linking threats to consequences**
- **Quantification of uncertainties**
- **“Credibility” definition of probability**
- **Bayesian inferential reasoning**

Our Meaning of Risk

Asking the question, “what is the risk of something” requires answers to the following questions:

- What can go wrong?
- If something goes wrong, how likely is it?
- What are the consequences?

Set of Triplets Definition of Risk

$$R = \{ \langle \mathbf{s}_i, \mathbf{L}_i, \mathbf{x}_i \rangle \}_c$$

Structuring the Scenarios

- **System analysis (success scenario)**
- **Threat analysis (initiating events)**
- **Vulnerability analysis (consequences)**

Linking of Threats and Consequences

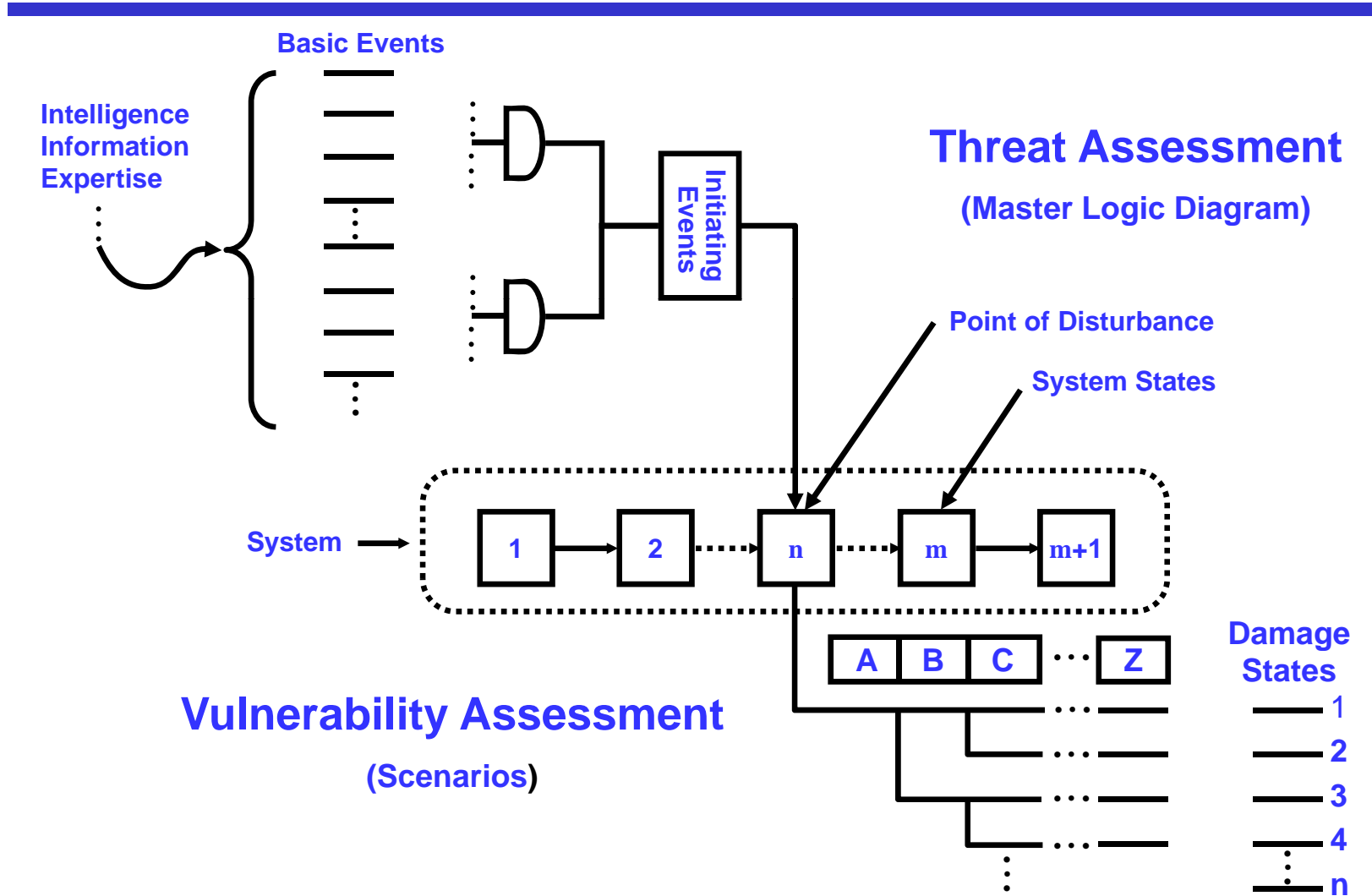

Threat Types

- **Internal:** Fires, explosions, equipment failure, operator error, instrument malfunction, criticality events, process malfunctions, power disruptions, structural failures, deliberate human acts, not following procedures
- **External:** Fires, loss of external power supplies, loss of other utilities, severe storms, sitewide pipeline and utility accidents, seismic events, hurricanes, tornadoes, nearby facility accidents, site intrusions, toxic gas releases, transportation accidents, volcanoes, surface geology, lightning, flooding events

Threat Categories

- **Disruptive Events:** Events that cause an immediate change to the facility. They are typically characterized by an event occurrence frequency and by directly measurable immediate consequences. Examples are severe storms, tornadoes, earthquakes, fires, and airplane crashes.
- **Nominal Events and Processes:** Expected events and natural processes that evolve continuously over the life of the facility. They are typically characterized by a rate, which may be constant or changing over time. The potential consequences from these processes depend on the duration of the exposure period. An example is the aging of engineered and natural systems.

Scenarios

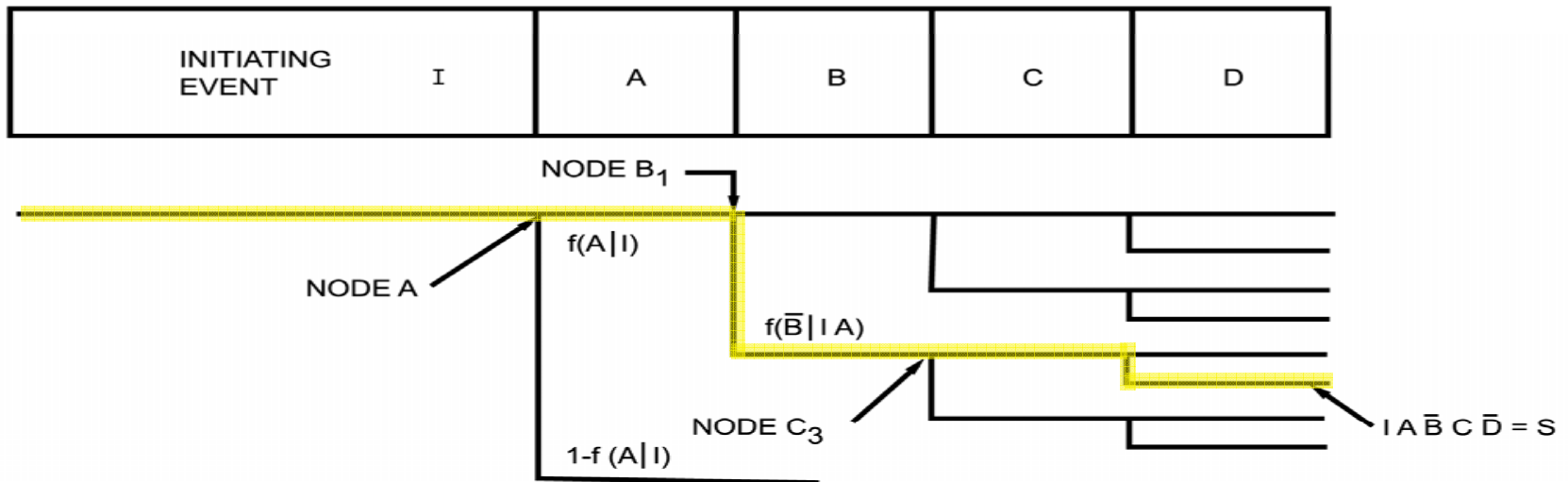

$$S = I A \bar{B} C \bar{D}$$

$$\phi(S) = \phi(I) f(A|I) f(\bar{B}|IA) f(C|IA\bar{B}) f(\bar{D}|IA\bar{B}C)$$

Quantification

SCENARIO
BOOLEAN
EQUATION

$$S = I\bar{A}\bar{B}\bar{C}\bar{D}$$

FREQUENCY
EQUATION

$$\phi(S) = \phi(I) f(A/I) f(\bar{B}/IA) f(C/I\bar{A}\bar{B}) f(\bar{D}/IABC)$$

UNCERTAINTY
PROPAGATION

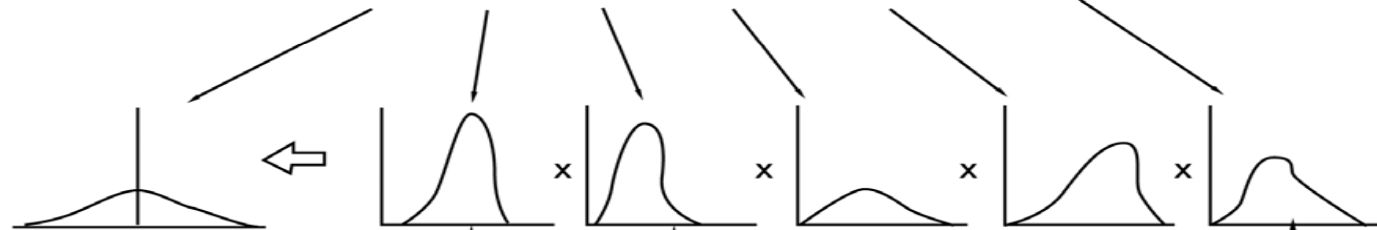

BAYESIAN
INFERENCE

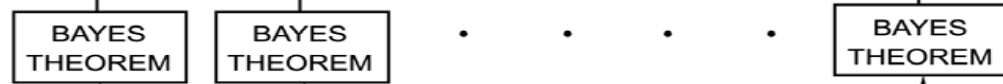

EVIDENCE
SETS



Probability and Bayes Theorem

- **Probability is the “credibility” of a hypothesis based on all the available evidence and is a positive number ranging from 0 to 1 that obeys Bayes theorem**
- **Bayes theorem answers the question, how does the probability of a given hypothesis change with new information**

Form of the Results for a Specific Consequence

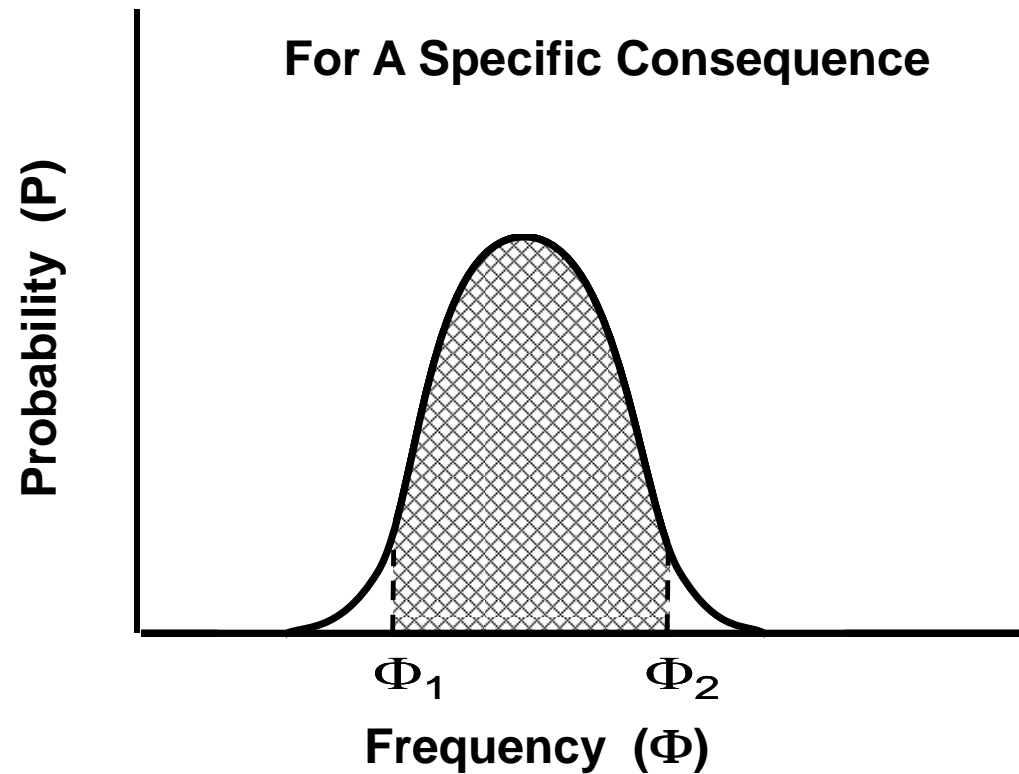

Form of the Results for Varying Consequences

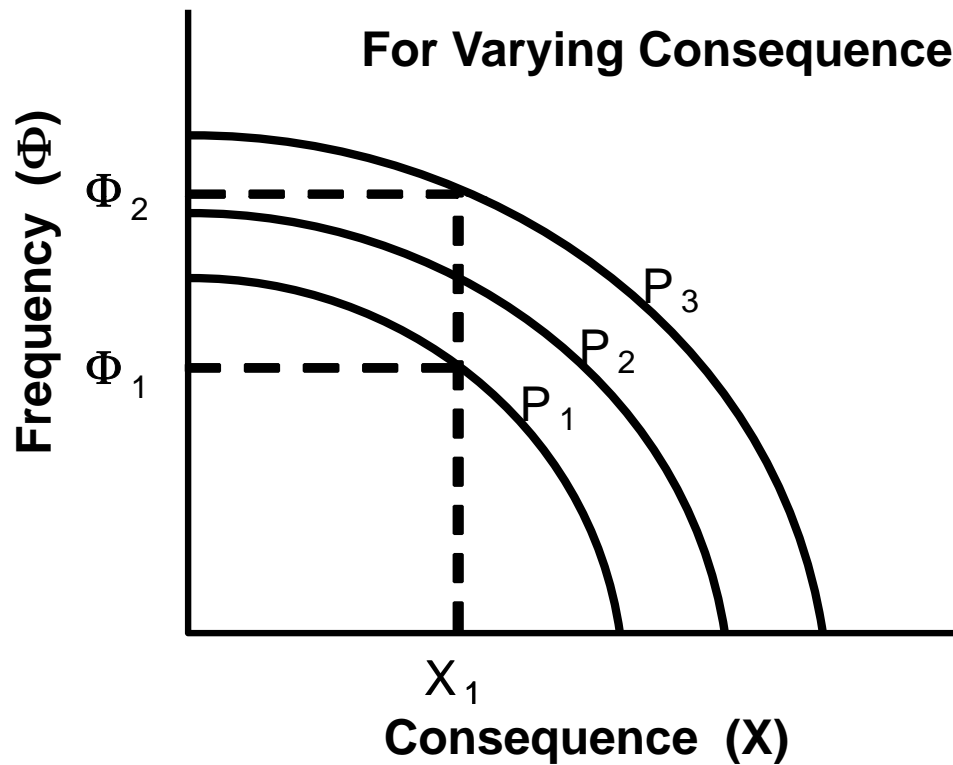

Safety Experience of Nuclear Fuel Recycling Plants

- **No operating plants in U.S.**
- **Plants in France, United Kingdom, Japan, and Russia**

Past U.S. Experience

- **Government plants in Savannah River, Hanford, and Idaho**
- **West Valley, New York**

Recycling Plant Incidents

- **Red oil incidents: Hanford 1953, Savannah River 1953 and 1957, Oak Ridge 1959, Canada 1980, and Russia 1993**
- **Criticality: Russia 1968 and Japan 1999**
- **Leaks, spills, and releases: All, including West Valley**
- **Waste tank explosion: Russia 1957**

Simplified PUREX Process Flow Chart

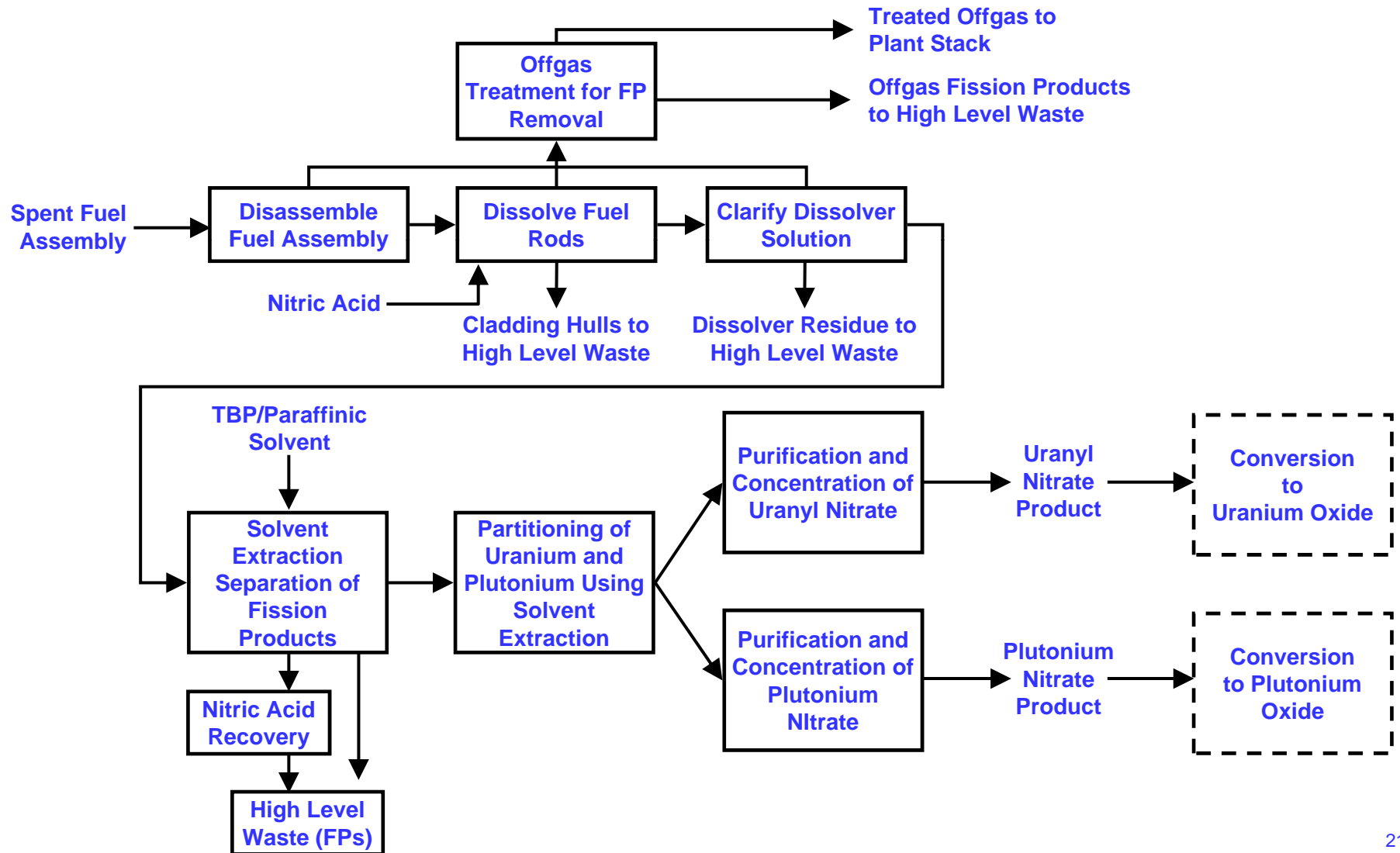

System Success Diagram

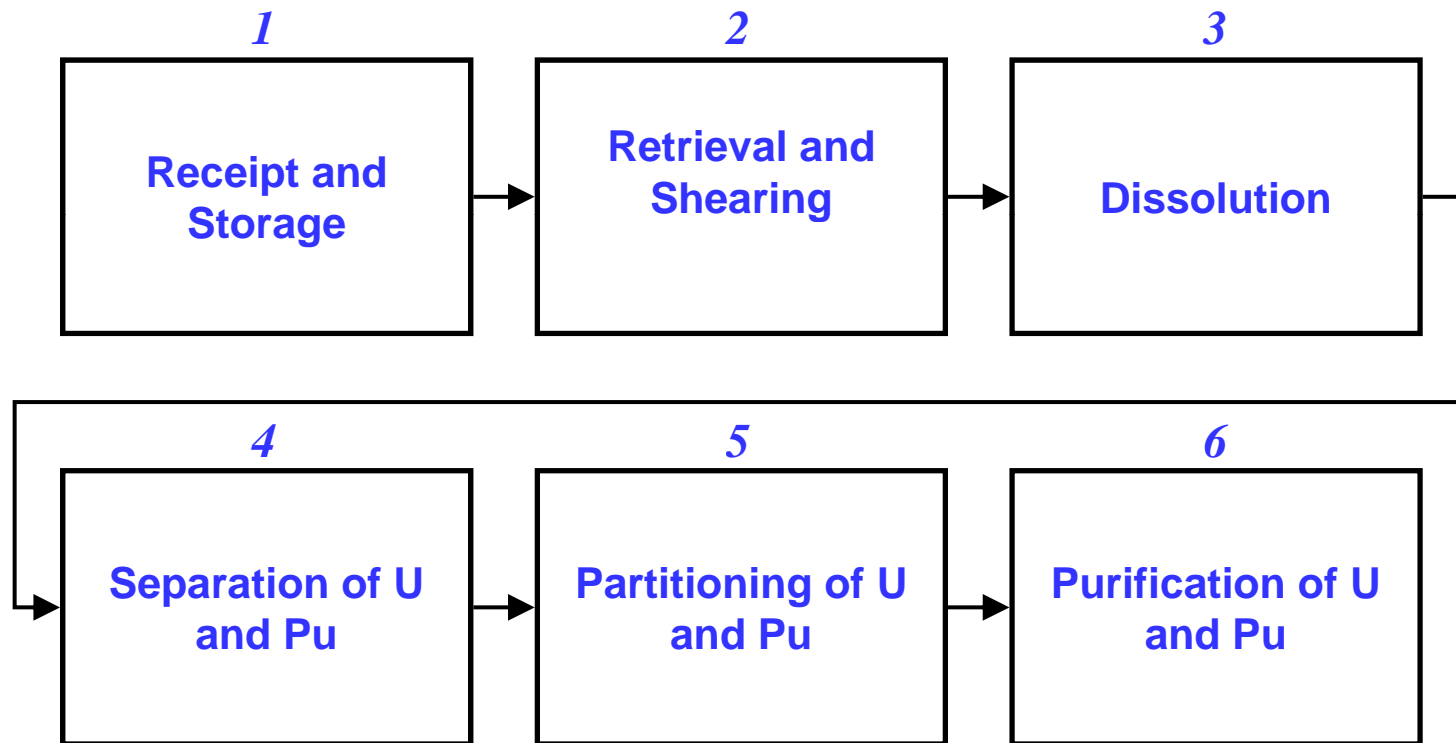

Concentration and Purification of U and Pu Nitrates

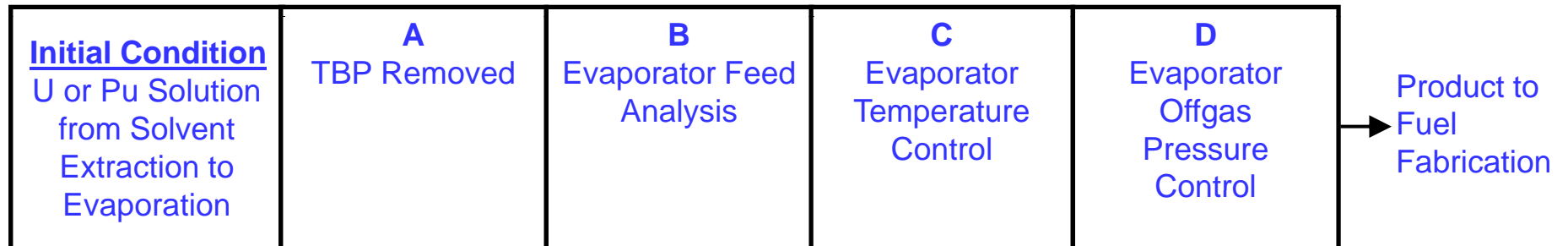

Event Tree for Red Oil Explosion Risk

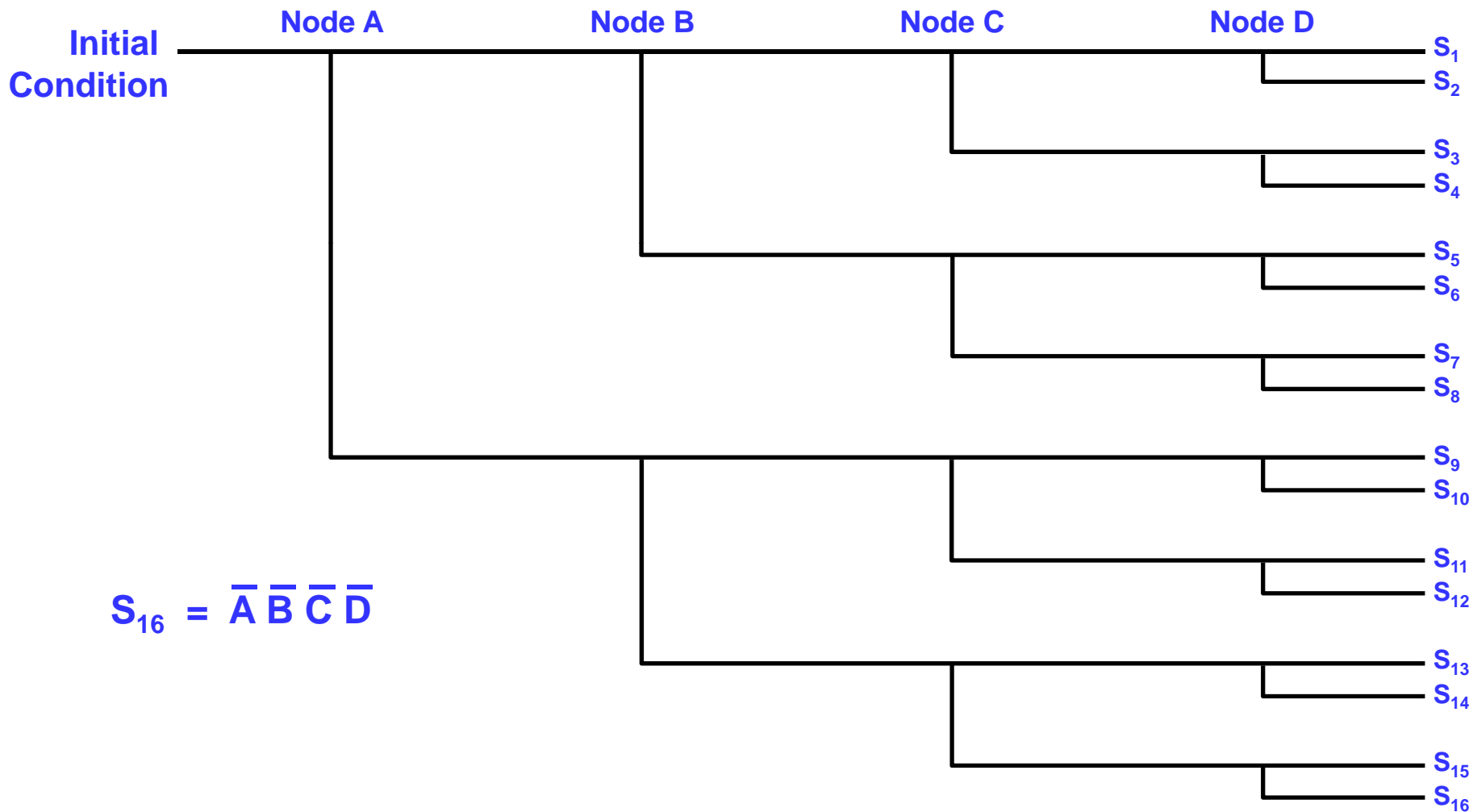

Summary of Scenarios and Consequences

Scenario	Description	Consequence or Outcome
S ₁	Evaporator systems operate as designed.	Product conforming to specification.
S ₂	All systems work except offgas system pressure fails high or low.	Off spec product.
S ₃	Evaporator temperature control fails high increasing heat input to evaporator; pressure control compensates for increased heat input.	Off spec product.
S ₄	Temperature control fails high; pressure control does not compensate.	Off spec product; possible nitrate precipitation in evaporate and shut down for repair.
S ₅	Evaporator feed analysis fails. All other systems function.	Possible off spec product.
S ₆	Evaporator feed analysis fails; evaporator pressure control fails.	Off spec product.
S ₇	Evaporator feed analysis fails; temperature control fails high; pressure control works.	Off spec product.
S ₈	Evaporator feed analysis fails; evaporator temperature control fails high; evaporator pressure control fails.	Off spec product; possible nitrate precipitation in evaporate and shut down for repair.
S ₉	Excess TBP in feed tank; feed analysis detects TBP.	Rework of evaporator feed required.
S ₁₀	Excess TBP in feed tank; feed analysis detects TBP; temperature control works; pressure control fails high or low.	Rework of evaporator feed required.
S ₁₁	Excess TBP in feed tank; feed analysis detects TBP; temperature control fails high; pressure control works.	Rework of evaporator feed required.
S ₁₂	Excess TBP in feed tank; feed analysis detects TBP; temperature control works; pressure control fails high or low.	Rework of evaporator feed required.
S ₁₃	Excess TBP in feed tank; feed analysis fails to detect TBP; temperature control works; pressure control works.	Off spec product; possible fire in fuel fabrication denitrator from TBP in product.
S ₁₄	Excess TBP in feed tank; feed analysis fails to detect TBP; temperature control works; pressure control fails high or low.	Off spec product; possible fire in fuel fabrication denitrator from TBP in product.
S ₁₅	Excess TBP in feed tank; feed analysis fails to detect TBP; temperature control fails; pressure control works.	Off spec product; possible fire in fuel fabrication denitrator from TBP in product.
S ₁₆	Excess TBP in feed tank; feed analysis fails to detect TBP; temperature control fails; pressure control fails high.	Red oil formation and possible overpressure or red oil explosion.

Fault Tree: Evaporator Feed

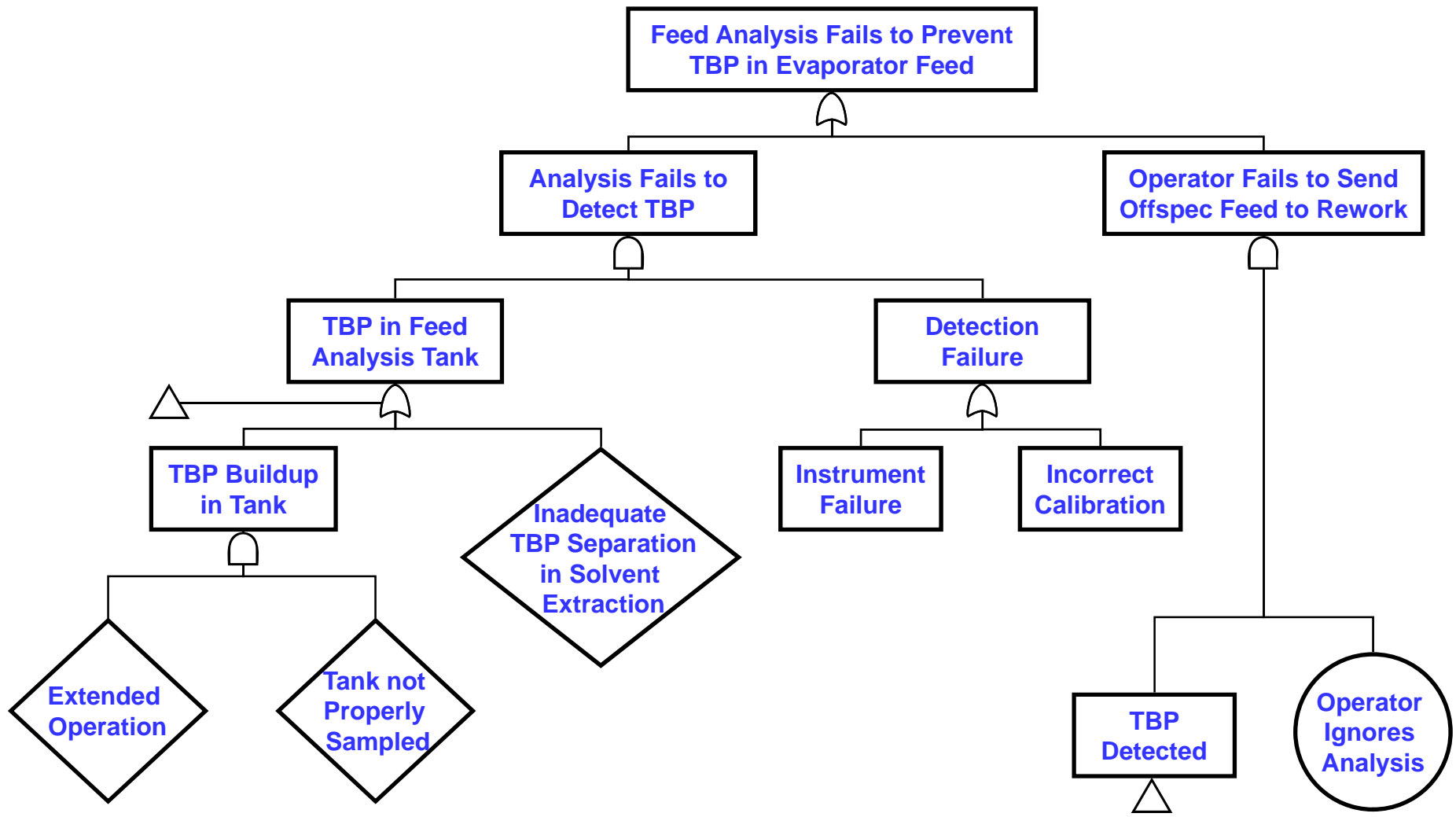

Fault Tree: Evaporator Temperature Control

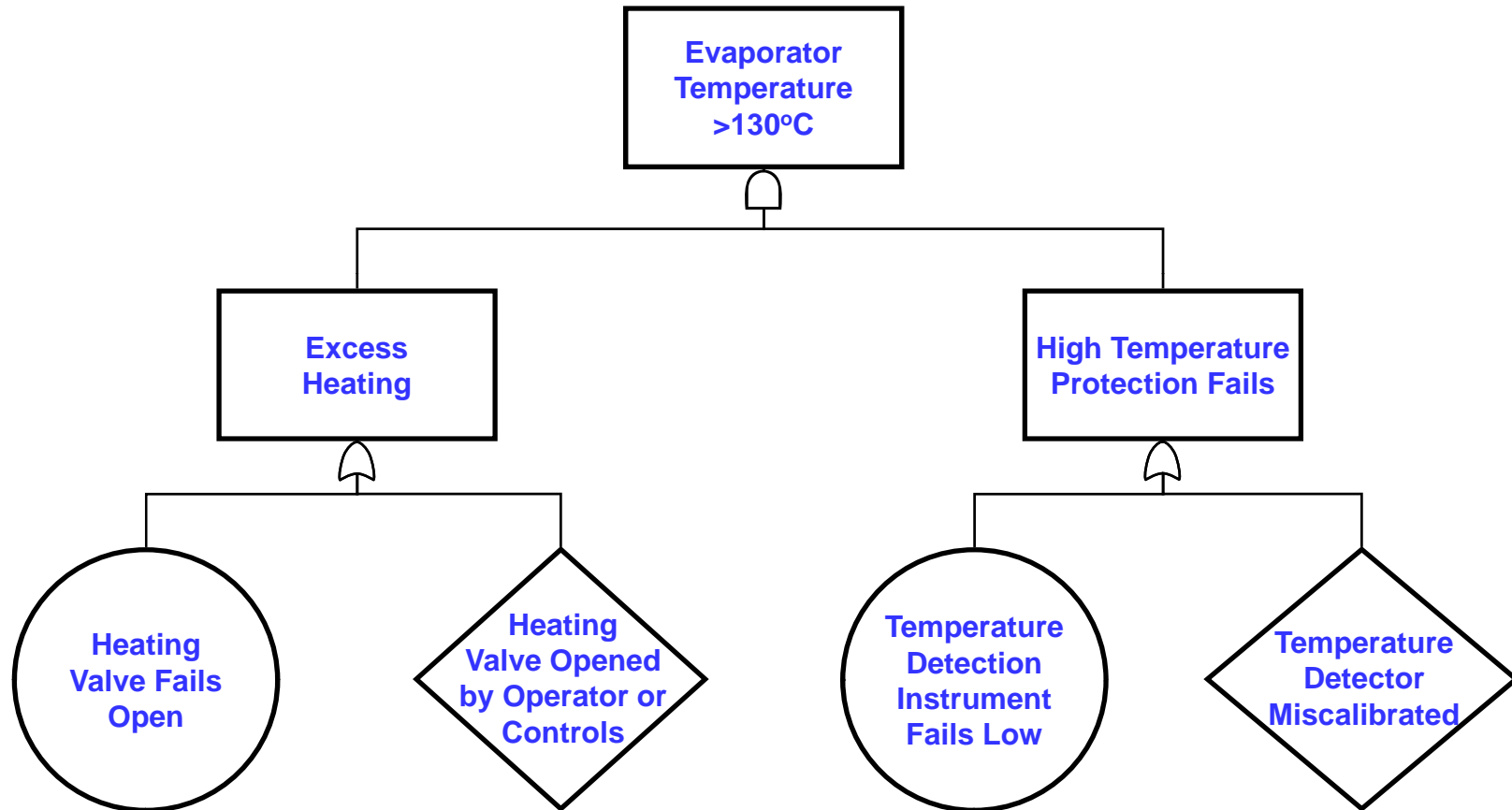

Quantification of Scenarios and Total Risk

- **Develop event probability distribution functions**
- **Convolute event PDFs into scenario PDFs**
- **Assemble scenarios into frequency of exceedance curves**

Summary and Conclusion

- **Provided a framework for quantitative risk assessment**
- **Highlighted applicability to nuclear fuel recycling facilities**
- **QRA has advanced to a high level of maturity**
- **QRA enhances risk management of any system**